



# What Happens to Heat Energy Reaching the Great Lakes?

Even as far back as the "log cabin days," people knew that water absorbs a great deal of heat energy and can in turn release this heat. Pioneers would prevent foods from freezing on cold nights by placing a large container of water in the room. Can you think of why this might work? In this investigation we will explore how bodies of water can affect the surrounding areas.

## OBJECTIVES

When you have completed this activity you will be able to:

- Describe how soil and water differ in their ability to absorb and release heat energy.
- Describe how this difference in heat absorbed or released affects the atmosphere immediately above the land and immediately above the water.

## Materials

Each lab group should have

- Four thermometers.
- A container of dark soil and one of water.
- Two 30 cm rulers.
- Masking tape.
- Ring stand.
- Graph paper.
- A light with reflector; the light should be at least 150 watts.

## Source

Modified from OEAGLS EP -1 "The effect of the Great Lakes on temperature" by James D. Meinke, Lakewood Public Schools; Beth A. Kennedy, Newark Public Schools, and Rosanne W. Fortner, The Ohio State University.

## Earth Systems Understandings

This activity focuses on ESU 3 and 4 (scientific process and interacting subsystems).

## Teacher's Notes

Set out the soil and water a day ahead to allow them to come to room temperature. Steps A-G of the procedure describe the experiment setup shown in Figure 1. It is also possible to demonstrate this in one aquarium with containers of soil (8x8 baking pan) and water.

Figure 1.

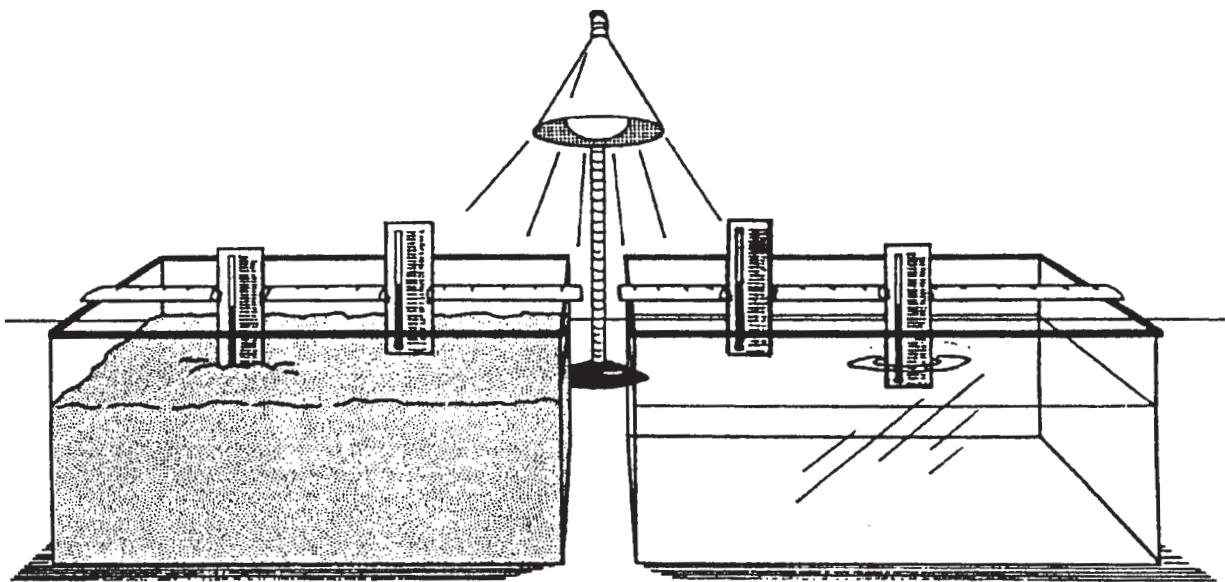

## Teacher's Notes

Answer to the question in the introduction. When a large container of water is placed in a room with foods, the water will prevent the foods from freezing since the water acts as a heat source if it is at a higher temperature than its surroundings. Water adds heat to the atmosphere, keeping the room warm.

1. Headings on their tables should be:
  - Time Elapsed
  - Thermometer 1 - above earth
  - Thermometer 2 - in earth
  - Thermometer 3 - above water
  - Thermometer 4 - in waterBelow Time Elapsed, have students number 1- 24 minutes.
- 2-4. To help make the graphs easier to interpret, it is best if all the initial temperature readings for the setup are the same. If the students' thermometers do not read the same at the beginning, then the temperature readings should be adjusted so that the initial temperatures are equal. This is done by finding the difference between the thermometer with the lowest reading and each of the others. The difference for each of the thermometers is then subtracted from each reading given by the thermometer.

## PROCEDURE

Set up your materials according to the following directions. (See Figure 1.)

- A. Place the containers of soil and water about 3 cm apart.
- B. Lay one ruler across each container, resting it on the container's rim.
- C. Place one thermometer in the soil with the thermometer bulb just barely covered. Attach with masking tape to the ruler.
- D. Place another thermometer close to the first one, but about 1 cm above the soil. Attach with masking tape to the ruler.
- E. Repeat steps C and D for the container of water.
- F. Place the lamp on a ring stand with the reflector pointing down.
- G. Position the lamp 30 cm above and centered between the containers.
- H. Be certain that the bulb of each thermometer is shielded from the direct rays of the lamp.

After your teacher has examined your setup, do the following:

1. Construct a data table to show the temperatures of the four thermometers each minute for at least 24 minutes.
2. Turn the lamp on. At one-minute intervals record the temperatures indicated on each of the four thermometers. Continue for 12 minutes.
3. Turn the lamp off after 12 minutes. Continue recording temperatures at one-minute intervals for 12 minutes.
4. Plot your data on the time-temperature graph that you construct. Use a different color for the data from each thermometer.

Answer questions 5-7 using data from the first 12-minute intervals on the data table and time-temperature graph. Put your answers on your work sheet.

5. With the light on, does air heat up faster over the soil or over the water?
6. Which changes more the temperature of soil or the temperature of the water?
7. Which absorbs more energy, soil or water?

Use the data for the last 12-minute intervals to answer questions 8-11.

8. With the light off, which changes more the temperature of soil or the temperature of the water?
9. Which changes most after the light is turned off, the temperature above the soil or the temperature above the water?
10. Which loses heat faster, soil or water?
11. Which keeps heat energy longest, soil or water?

Anything that adds heat energy to the atmosphere is called a *heat source*. A *heat sink* takes and stores energy from the atmosphere.

12. Could soil or water be considered a heat sink while the light was on? Discuss.
13. After the light was turned off, was the soil a heat source? Was the water a heat source? Discuss.

## Answers

5. The air heats up faster over the soil.

6 and 8. While the lamp is on, the soil should be heating up more rapidly than the water since soil has a lower specific heat, and it absorbs all radiation close to the surface. **Specific heat** is the amount of heat (in calories) required to raise the temperature of 1 gram of substance by 1 degree Celsius. The specific heat of water is 1. For all other common liquids and solids, the specific heat is less than 1.

After the light is turned off, the soil should cool more rapidly than the water because of its lower specific heat. (See Figure 2.) Note that the curves for soil and water now show a drop at different rates in Section B of the graph. Most students should be able to notice the difference in this part of their data curves.

7 and 9. The water will absorb more energy. It will be very difficult for students to understand this. The clue is in the "air" curves. The air over the soil heats up much more rapidly than that over the water. This is because soil cannot hold onto the heat energy and gives it right back to the atmosphere. The difference in the two curves therefore implies that the water has a greater capacity for storing heat energy. This idea is further supported by the ends of the two curves. Note that they cross at about 19 minutes and continue to diverge after that. Water is acting as a source of heat energy for the atmosphere.

10. Soil loses heat faster than water.

11. Water keeps its energy the longest. If students place their thermometers too deeply in the soil, their temperatures will show a continuing rise in temperature after the light is turned off. This happens because some of the energy from the surface is conducted downward into the soil.

## Answers

12. Normally soil will function very briefly as a heat sink after the light is turned on. Shortly, however, it will begin radiating energy back to the atmosphere (become a heat source) as indicated by the heating of the air above the soil. Water should remain a heat sink, however, and produce only a minimum rise in temperature of the air above. Figure 2 does not show this relationship.
13. After the light is turned off, soil functions only briefly as a heat source. Water, however, continues as a source to the end of the recording period. Since the air temperature above the water remains higher than that of the water itself, it will continue to act as a heat source until the surface water is the same temperature as the air over it.
14. C.
15. D.
16. B.
17. A heat sink is a substance or object that is absorbing more heat than it is radiating.
18. A heat source is a substance or object that is radiating more heat than it is absorbing.
14. A heat sink
- a. has a higher temperature than its surroundings.
- b. "gives off" excess heat.
- c. absorbs and stores excess heat.
- d. is the Great Lakes in the wintertime.
15. If you place a bucket of water and a bucket of soil out in the sun in the morning, what would happen to their temperature?
- a. Their temperature would not change.
- b. Both would warm up at the same rate.
- c. Water would warm up faster than the soil.
- d. Soil would warm up faster than the water.
16. If you kept the same two buckets outside until after the sun set, that would happen to the temperatures?
- a. Both would cool at the same rate.
- b. Soil would cool faster.
- c. Water would cool faster.
- d. Their temperature would not change.
17. Define in your own words the term "Heat Sink."
18. Define in your own words the term "Heat Source."
19. Predict how you think the Great Lakes affect temperature.

## Technology Extension

Use the Internet to collect temperature data from around the Great Lakes area. Kids as Global Scientists and U M Weather make accessing weather information simple. Check out these two addresses.  
<http://groundhog.sprl.umich.edu/kgs01.html>  
<http://cirrus.sprl.umich.edu/wxnet/>  
Since addresses commonly change, try a keyword search on the names of the programs, shareware software, or weather software to locate new addresses.

## REFERENCES

- American Geological Institute, 1987. *Investigating the Earth*, Boston: Houghton Mifflin Company. This activity is adapted from an investigation in this volume.
- Eichenlaub, Val L., The Effect of Lake Erie on Climate, in Fortner, R.W. and V.J. Mayer, eds. *The Great Lake Erie*, Chapter 4, Columbus: The Ohio State University, Ohio Sea Grant College Program.

Figure 2. Sample of student graph results.

